

Specification Sheet

SilenX Xtrema Pro - 40x40x20mm DC Axial Fan - IXP-13-14

Mechanical Drawing

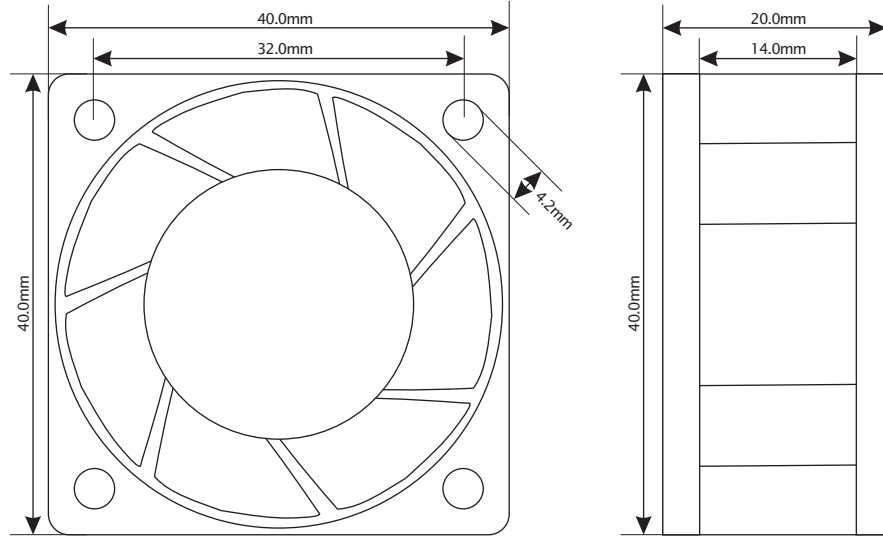

Mechanical Properties

SKU	IXP-13-14
Rated Voltage	12.0 v
Operating Voltage Range	8.0~14.0 v
Rated Current	0.03 A
Rated Power	0.36 w
Rated Speed	3200 RPM
Airflow	5.7 CFM
Static Pressure	2.32 mm H ₂ O
Noise Level, 1m, xyz axes avg	13.5 dBA
Noise Level, 1m, z axis	14.1 dBA
Operating Temperature	-10°/+70° C
Storage Temperature	-40°/+80° C
Bearing	Fluid Dynamic
Weight	0.8 oz

MTBF Hours	L50	L10
Temperature		
30° C	235434	101586
40° C	163186	70412
50° C	115705	49925
60° C	83751	36137
70° C	61775	26655

RoHS Certificate of Compliance:

As of February 2, 2006

This "RoHS Certificate" provides information regarding the absence of certain substances in the SilenX Xtrema Pro Fan model listed on this document.

The models identified below are in compliance with the European Union Directive 2002/95/EC on the restriction of use of certain hazardous substances ("RoHS Directive"). The models do not contain any of the restricted substances referred to in the European Union Commission Decision of August 18, 2006 (2005/618/EC) in connection with Articles 4 and 5 of the RoHS Directive in concentrations in excess of the values permitted thereunder.

For purposes of this RoHS Certificate, the maximum concentration values of the restricted substances by weight of homogeneous materials are:

- hexavalent chromium 1,000 ppm
- poly-brominated biphenyls (PBB's) 1,000 ppm
- poly-brominated diphenyl ethers (PBDE's) 1,000 ppm
- cadmium 100 ppm
- mercury 1,000 ppm
- lead 1,000 ppm

Pressure curve for IXP-13-14



Notes:

Comes standard with 300mm 30AWG wires terminated by Molex 22-01-2035 or equivalent.

Fan tachometer, 3rd wire RPM sensor, comes standard.

Conforms to CE - Reference 73/23/EEC Low Voltage Directive.

Fan housing and fan blade resin flammability conforms to class UL-94V-2.